

# **NOVALYNX CORPORATION**

**200-WS-23 WIND SPEED & DIRECTION  
200-WS-23-M WIND SPEED & DIRECTION  
200-WS-23S WIND SPEED ONLY**

**CURRENT LOOP WIND SENSOR**

**INSTRUCTION MANUAL**

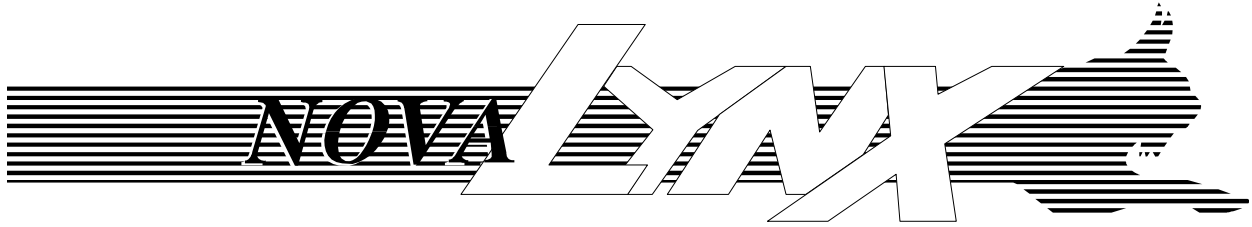

REVISION DATE: JULY 2010

## **Receiving and Unpacking**

Carefully unpack all components and compare to the packing list. Notify NovaLynx Corporation immediately concerning any discrepancy. Inspect equipment to detect any damage that may have occurred during shipment. In the event of damage, any claim for loss must be filed immediately with the carrier by the consignee. Damages to equipment sent via Parcel Post or UPS require the consignee to contact NovaLynx Corporation for instructions.

## **Returns**

If equipment is to be returned to the factory for any reason, call NovaLynx between 8:00 a.m. and 4:00 p.m. Pacific Time to request a Return Authorization Number (RA#). Include with the returned equipment a description of the problem and the name, address, and daytime phone number of the sender. Carefully pack the equipment to prevent damage or additional damage during the return shipment. Call NovaLynx for packing instructions in the case of delicate or sensitive items. If packing facilities are not available take the equipment to the nearest Post Office, UPS, or other freight service and obtain assistance with the packaging. Please write the RA# on the outside of the box.

## **Warranty**

NovaLynx Corporation warrants that its products are free from defects in material and workmanship under normal use and service for a period of one year from the date of shipment from the factory. NovaLynx Corporation's obligations under this warranty are limited to, at NovaLynx's option: (i) replacing; or (ii) repairing; any product determined to be defective. In no case shall NovaLynx Corporation's liability exceed product's original purchase price. This warranty does not apply to any equipment that has been repaired or altered, except by NovaLynx Corporation, or that has been subjected to misuse, negligence, or accident. It is expressly agreed that this warranty will be in lieu of all warranties of fitness and in lieu of the warranty of merchantability.

## **Address**

**NovaLynx Corporation**  
**4055 Grass Valley Highway, Suite 102**  
**Auburn, CA 95602**  
**Phone: (530) 823-7185**  
**Fax: (530) 823-8997**  
**Email: [nova@novalynx.com](mailto:nova@novalynx.com)**  
**Website: [www.novalynx.com](http://www.novalynx.com)**

Copyright © 1988-2010 by NovaLynx Corporation

# TABLE OF CONTENTS

Section No.	Page No.
1.0 INTRODUCTION .....	1
1.2 Physical Description .....	1
1.2.1 The Wind Sensor .....	1
1.2.2 The Encoder .....	1
2.0 SPECIFICATIONS .....	2
3.0 THEORY OF OPERATION .....	2
3.1 Wind Speed Measurement .....	2
3.2 Wind Direction Measurement .....	3
4.0 INSTALLATION .....	3
4.1 Unpacking .....	3
4.2 Wind Sensor Installation .....	4
4.3 Transmitter Installation .....	4
5.0 OPERATIONAL TESTING .....	5
5.1 Circuit Board Adjustments .....	6
6.0 MAINTENANCE .....	6

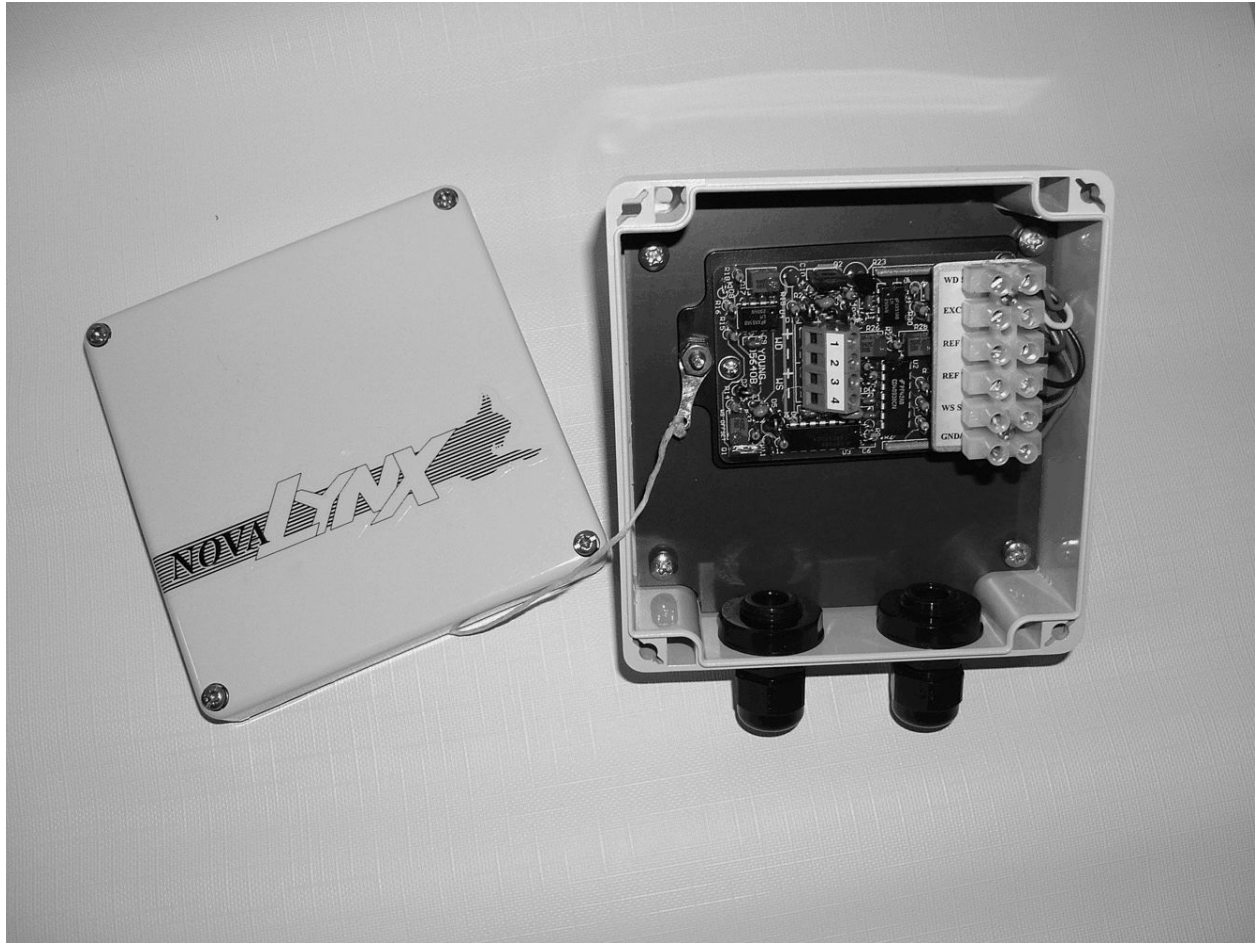

200-WS-23 Wind Speed & Direction 4-20 mA Output Circuit and Enclosure



200-WS-02F Wind Speed & Direction Sensor



200-WS-01B Wind Speed Sensor

# **NovaLynx Corporation**

## **200-WS-23 & 200-WS-23S Current Loop Wind Sensor Instruction Manual**

### **1.0 INTRODUCTION**

The NovaLynx 200-WS-23 Current Loop Wind Sensor measures wind speed and direction and converts each measurement into a 4-20 mA output signal for use by process controls or monitoring systems. External power is not required since the encoding electronics for wind speed and for wind direction are isolated and powered from their respective 2-wire current loops. NovaLynx offers two versions of the wind sensor; the 200-WS-23 measures both wind speed and direction, while the 200-WS-23S measures only wind speed. Both models contain two subassemblies; the wind sensor and the signal conditioning electronics assembly.

The 200-WS-02F Wind Speed & Direction Sensor used with the WS-23 includes a three-cup anemometer and a wind vane. The WS-23S uses the 200-WS-01B Wind Speed Sensor, which consists of the same anemometer without the wind vane. The sensor is ruggedly constructed using UV-resistant ABS plastic and anodized aluminum parts. The cable connecting the pole-mounted wind sensor to the encoder electronics package is typically 40 feet in length but may be extended for a total length of 250 feet. The encoded current loop signals are capable of being transmitted over distances of up to several miles. The electronics package is supplied inside a gasketed NEMA enclosure.

### **1.2 Physical Description**

#### **1.2.1 The Wind Sensor**

The wind sensor is the rotating assembly with the three cup anemometer and wind vane for measuring wind speed and wind direction. The wind vane is mounted onto a common axis with the anemometer and includes a tail fin with a nose weight that provides balance. The wind vane is coupled to an angular encoder that is housed within the sensor's cylindrical weather skirt.

#### **1.2.2 The Encoder**

The encoder electronics package is housed within a gasketed NEMA enclosure. The circuitry contains two independent 4-20 mA data channels, one for wind speed and one for wind direction. Each channel receives its power from its respective 2-wire measurement loop.

## 2.0 SPECIFICATIONS

### SENSOR

#### Wind Speed

Measurement range	0-100 mph (standard) 0-50 m/s, 0-100 knots, or 0-200 km/hr (optional)
Speed constant	1.25 mph = 1 pps 75 mph = 60 Hz (pps)
Transducer type	Reed switch
Speed threshold	0.8 mph
Accuracy	1 mph or $\pm 3\%$

#### Wind Direction

Range	0-360 degrees azimuth
Transducer type	Potentiometer, 20k ohms, conductive plastic
Potentiometer gap	5°
Azimuth accuracy	$\pm 3^\circ$
Threshold	1.2 mph
Bearings	Bushing

### TRANSMITTER UNIT

Current loop output span	4 to 20 mA, proportioned to 0-100 mph & 0-360° (std)
Supply voltage range	8 to 30 Vdc
2-wire loop interface	Screw terminal block
Interface power	Derived from current loop
Operating temperature	-58° to +122° F (-50° to + 50° C)

### GENERAL

Mounting	1" o.d. pipe
Cable WS-02F (WS/WD)	5 conductor, 24 AWG, shielded, 40' standard
Cable WS-01B (WS)	2 conductor, 24 AWG, shielded, 40' standard
Dimensions	
200-WS-23 (WS/WD)	12" H x 10" W
200-WS-23S (WS)	4.5" H x 8.5" W
Electronics enclosure	4.7" H x 4.7" W x 2.25" D
System weight/shipping	5 lbs/7lbs

## 3.0 THEORY OF OPERATION

### 3.1 Wind Speed Measurement

The 200-WS-23 wind sensor has been designed to provide measurement of wind speed and wind direction. Wind speed is measured by a rotating assembly of three cups. The three cups are attached onto a central shaft that supports the cups as well as

provides a mounting point for the sensor's ball bearing. The ball bearing provides smooth rotation of the cups and helps produce an accurate measurement. The anemometer's precision ball bearing is protected from the weather and has lifetime lubrication. The rotation of the cups is sensed by a magnetically activated switch. The switch is in a fixed position while three magnets are fastened to the rotating cup housing. The number of switch closures per rotation is converted into a frequency that is proportional to the wind speed in miles per hour. The full-scale (20 mA) output of the wind speed channel represents a measurement of 100 mph.

### **3.2 Wind Direction Measurement**

Wind direction is measured by a rotating device as well. The wind vane rotates about its central shaft in response to changes in the wind's direction. The counterweight at the end of the wind vane nose balances the weight of the moving mass over its supporting bearing. It is important that the wind sensor be installed in a location free from any obstructions that would distort the natural flow of air across the sensor. The vane's rotation is transmitted to a stationary potentiometer located inside the sensor housing. As the shaft rotates, the resistance of the potentiometer at its wiper changes. The sensor has been designed to produce an increasing resistance as the wind direction increases from zero to 360 degrees azimuth. From above the sensor this increase in direction will appear as a clockwise rotation of the vane. The opposite is true for a decreasing wind direction. A wind changing from 360 towards zero degrees results in a decrease in resistance and a counterclockwise rotation.

Application of a voltage across the potentiometer allows measurement of the wind direction as a changing voltage. The voltage changes are converted by the encoder circuitry into a proportional 4 to 20 milliampere signal with 4 mA equal to zero degrees and 20 mA equal to 360 degrees. The full-scale span of the direction channel means that the vane nose is pointing toward 360 degrees or North.

The potentiometer used as a direction sensor for wind direction has an arc of resistance discontinuity or "deadband" (typically 5°). The deadband is located between the 360 degree and the 0 degree points (North is indicated by the set screw in the mounting base). Typically, the deadband is centered on the North point. This means that the sensor really does not measure zero degrees but instead starts measuring at 2 to 5 degrees. Similarly, the end of the direction measurement occurs at 355 to 357 degrees and not exactly at 360. When the wind vane is pointing in this region the loop current will be encoded as an full scale value of approximately 20 mA.

## **4.0 INSTALLATION**

### **4.1 Unpacking**

Empty the loose packing material from the corrugated shipping container and carefully lift out the wind sensor assembly. Refer to the warranty page at the front of this manual for information regarding returning damaged or incorrect equipment. The tail is normally removed for shipping. Re-attach with the 2 screws to the vane arm.

The following items should be included in the shipping container:

200-WS-02F Wind Speed & Wind Direction Sensor, with 40 feet of cable

or

200-WS-01B Wind Speed Sensor, with 40 feet of cable

Transmitter Housing Assembly

Instruction Manual

## **4.2 Wind Sensor Installation**

Choose a mounting location for the wind sensor that is free from obstructions. Use extreme care to prevent contact with electrical power lines while erecting the unit. A typical installation will position the wind sensor approximately 33 feet (10 meters) above the highest obstacle within a 990 foot (300 meter) radius of the mounting location. Position the 200-WS-23 sensor onto the end of a 1" o.d. TV mast tubing or a 3/4" Schedule 40 pipe. If the pole is metal it should be electrically grounded to minimize the probability of any lightning damage. Rotate the anemometer on the pole so that the two set screws on the anemometer base are facing North. Magnetic North is adequate for most installations. Should a True North alignment be required, the magnetic declination at the sensor location must be known and applied to the compass reading. Tighten the bottom set screw to fix the directional orientation.

## **4.3 Transmitter Installation**

Mount the transmitter enclosure in a location where it can be conveniently connected to the wind sensor.

Route the sensor signal cable in the most direct manner possible. Avoid sharp corners and edges. Do not crease or fold the cable. The cable must be protected from high winds. Use an appropriate fastener (plastic cable ties, staples, etc.) to secure the cable to its support structure. Use care to avoid puncturing the cable jacket if staples are used.

The standard wind sensor is supplied with 40 feet of cable. In the event that the interconnecting cable needs to be extended, use good splicing techniques and waterproof the splice if it will be exposed to the weather. The cable to the wind sensor may be extended to up to 250 feet in length without degrading the accuracy of the sensor's measurements. The output cable running from the transmitter enclosure for the current loop is not provided with the equipment. The current loop power supplies are also not furnished with the standard unit. The cable and power supplies are required for operation of the equipment and are generally customer furnished items.

I/O connection terminal strips are located on the printed circuit board. Terminal functions along with the corresponding colors of the wind sensor interconnecting cable

are shown in the table below. The cable supplied is a 5-conductor WS/WD or 2-conductor WS, 24AWG, shielded, outdoor grade cable.

### SENSOR WIRING

●1	<input type="radio"/>	Wind Dir Sig - Green	●1	<input type="radio"/>	
●2	<input type="radio"/>	Wind Dir EXC - Red	●2	<input type="radio"/>	
●3	<input type="radio"/>	Wind Dir Ref - Black	●3	<input type="radio"/>	
●4	<input type="radio"/>	Wind Speed Ref - Brown	●4	<input type="radio"/>	Wind Speed Ref - Black
●5	<input type="radio"/>	Wind Speed Sig - White	●5	<input type="radio"/>	Wind Speed Sig - Red
●6	<input type="radio"/>	Earth Ground - Shield	●6	<input type="radio"/>	Earth Ground - Shield
●1	<input type="radio"/>	Wind Direction 4-20 mA Loop +	●1	<input type="radio"/>	
●2	<input type="radio"/>	Wind Direction 4-20mA Loop -	●2	<input type="radio"/>	
●3	<input type="radio"/>	Wind Speed 4-20mA Loop +	●3	<input type="radio"/>	Wind Speed 4-20mA Loop +
●4	<input type="radio"/>	Wind Speed 4-20mA Loop -	●4	<input type="radio"/>	Wind Speed 4-20mA Loop -

Wind Speed & Direction 200-WS-23  
5 Conductor Sensor Cable

Wind Speed Only 200-WS-23S  
2 Conductor Sensor Cable

## 5.0 OPERATIONAL TESTING

Connect the speed and wind direction 4-20mA loop circuits to the appropriate locations of the terminal strip of the printed circuit board as shown in the above chart. For test purposes, you may wish to use an unregulated but filtered source of 10 to 24 volts dc power having a precision 100 ohm resistor (preferably  $\pm 1\%$  accuracy) connected in series with the supply. The loop powered encoding circuits require the proper polarity of loop current; however diodes are included to protect the circuitry against reversed polarity connections.

Connect the test leads of a digital voltmeter across the resistor to measure the plc loop current. The measured wind speed and direction at several cardinal calibration points are shown in the following table:

Wind Direction (Deg Az)	Wind Speed (mph)	Loop Current (mA)	V <sub>100Ω</sub> (Volts)
N+	0.0	4.0	0.4
NE = 45°	12.5	6.0	0.6
E = 90°	25	8.0	0.8
SE = 135°	37.5	10.0	1.0
S = 180°	50	12.0	1.2
SW = 225°	62.5	14.0	1.4
W = 270°	75	16.0	1.6
NW = 315°	87.5	18.0	1.8
N-	100	20.0	2.0

### 5.1 Circuit Board Adjustments

Multiple turn potentiometers located on the printed circuit board are provided for independent gain and offset adjustment for both the speed and direction channels as shown in the table below:

	Offset	Span
<b>Wind Speed</b>	R-33	R-17
<b>Wind Direction</b>	R-26	R-28

The 200-WS-23 normally should not require adjustment of these controls. An exception occurs if for any reason the wind sensor is changed or if the cabling to the wind sensor exceeds 200 feet in length. In these cases the span control of the direction channel may require a slight adjustment.

The wind speed channel does not normally require any adjustments in the field.

The wind sensor output signal is a reed switch closure. There are three switch closures for each revolution of the cup assembly. Rotating the cups by hand and using a swift spin will produce a wind speed output of 10 to 20 miles per hour.

## 6.0 MAINTENANCE

Maintenance of the wind sensor assembly is limited. Periodic but regular inspections of the equipment is necessary to prevent damage due to loose or missing hardware. Wind sensors experience many vibrations due to high velocity winds blowing through the tower and mast support structure. These vibrations can cause mounting hardware to

become loose and to fall out. Tighten any loose hardware and replace any missing hardware.

Inspect the sensor cable as well to detect any damage due to wind whipping. Replace any damaged cables immediately, especially if there are exposed wires. Cracked and weathered cable jackets are not usually a problem as long as the cable is securely fastened by wire ties. Check wire ties and replace any that have become loose or that are missing.

Check for damage to the anemometer cups and the vane tail. Replace any cup assembly that has been damaged.

Remove all dust, dirt, mud, bird droppings, etc., that may have been deposited onto the cups and vane tail. Repair or replace bent tails. Check the counterweight of the wind direction sensor. Repair the vane arm if the counterweight is loose. The counterweight is held in place by epoxy.

Apply several drops of light weight (3-in-1) machine oil or lightly spray WD40 onto the anemometer bearing located just below the cups.

Always look at the wind vane alignment to North. If the alignment is critical, do the check with a compass. Make corrections to the alignment as needed. Always check the alignment after a severe storm with high velocity winds.

Check the equipment that the sensor is connected into. Make sure that there are signals coming from the sensor. Test the signals to be certain that the measurements are accurate.

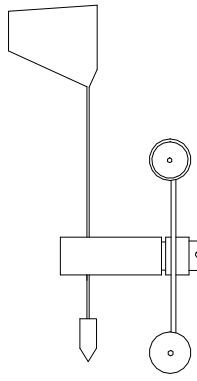

0-100 mph  
0-360 deg Az

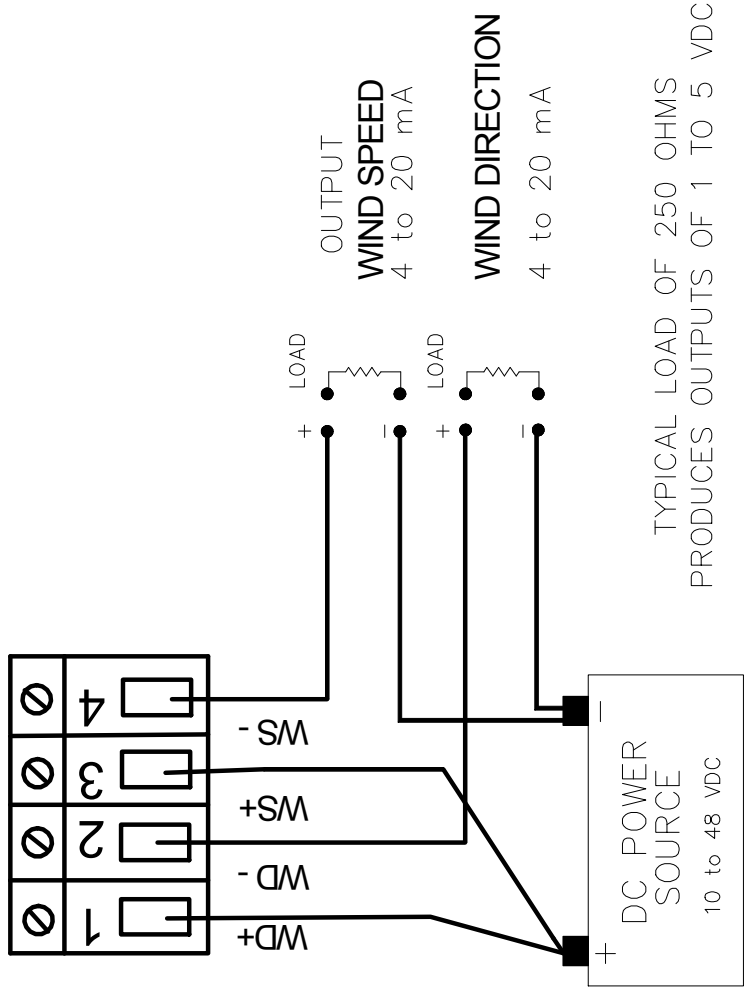
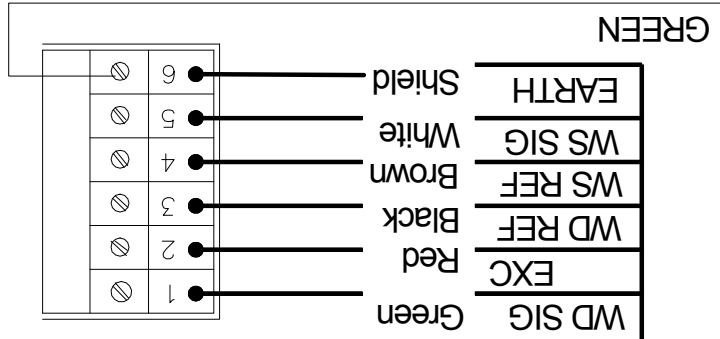

OUTPUT  
**WIND SPEED**  
4 to 20 mA

**WIND DIRECTION**  
4 to 20 mA

TYPICAL LOAD OF 250 OHMS  
PRODUCES OUTPUTS OF 1 TO 5 VDC

**WARNING!**  
Warranty is void if  
GREEN WIRE is not  
connected to earth ground.

## MODEL 200-WS-23

CURRENT LOOP WINDSTATION  
TYPICAL WIRING WITH A SINGLE POWER SOURCE

TITLE SCHEMATIC, TYPICAL WIRING WITH SINGLE POWER SOURCE	
MODEL USAGE 200-WS-23	SHEET 1 OF 1
BY cna	SCALE DWG. NO.
DATE 11/10/2006	NONE 10000338

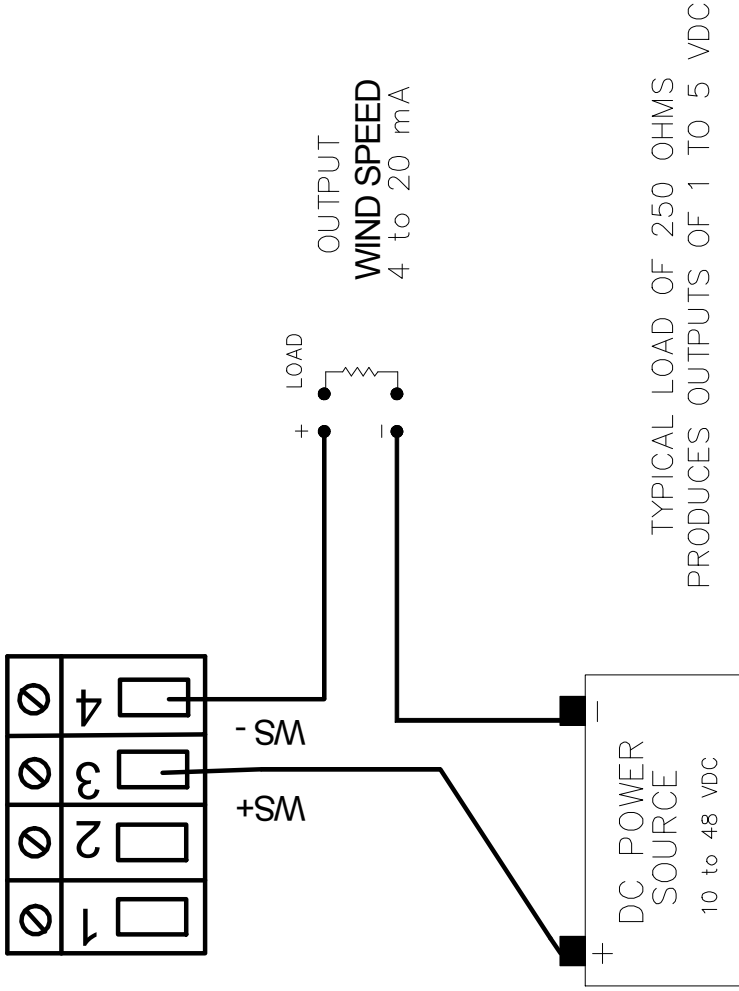

TYPICAL LOAD OF 250 OHMS  
PRODUCES OUTPUTS OF 1 TO 5 VDC

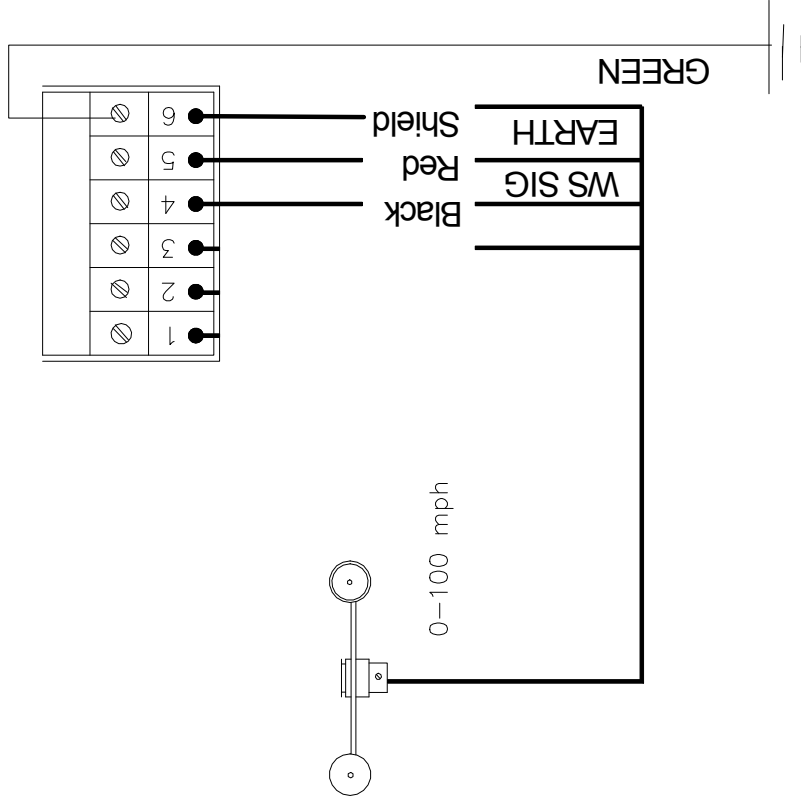

**WARNING!**  
Warranty is void if  
GREEN WIRE is not  
connected to earth ground.

## MODEL 200-WS-23S

CURRENT LOOP WINDSTATION  
TYPICAL WIRING WITH A SINGLE POWER SOURCE

TITLE	SCHEMATIC, TYPICAL WIRING WITH SINGLE POWER SOURCE
MODEL USAGE	200-WS-23S SHEET 1 OF 1
BY	chn
DATE	7/8/2010
SCALE	DWG. NO. NONE
	10000338