

NovaLynx Corporation

INSTRUCTIONS

APPENDIX A
BAROMETER
TYPICAL WIRING CONNECTIONS

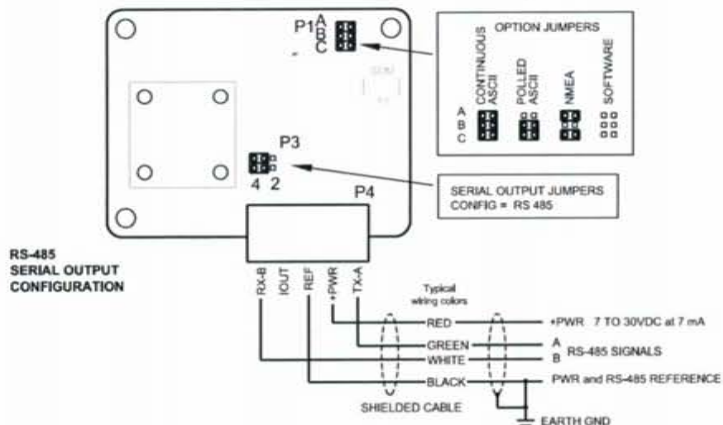
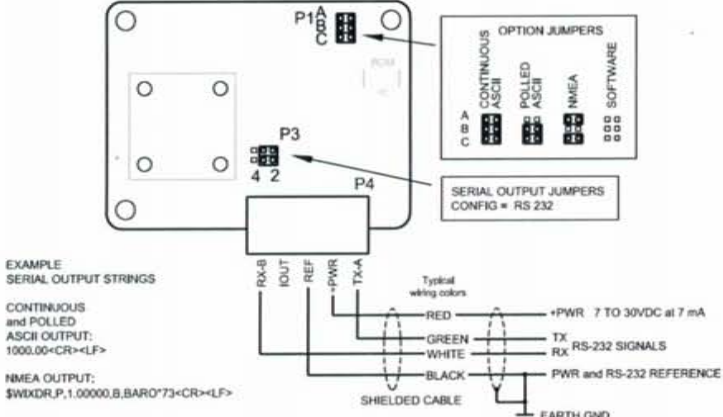
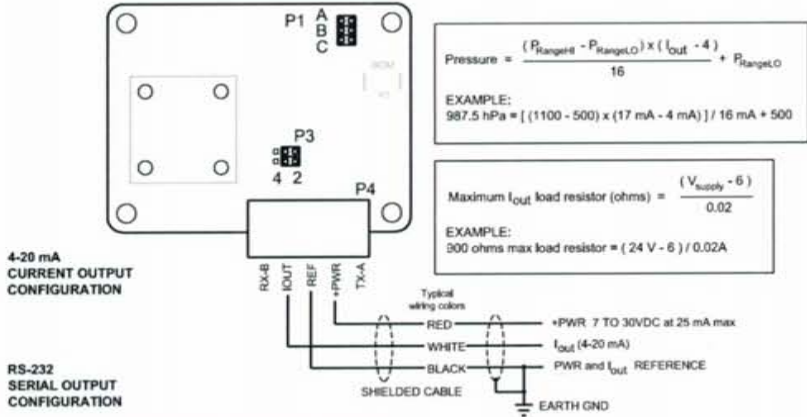

Models 230-600C and 230-601C

230-600C Barometric Pressure Sensor, 4-20mA output

230-601C Barometric Pressure Sensor, 4-20mA output
 Mounted in polycarbonete enclosure, with 25' cable,

1.0 SPECIFICATIONS

Pressure 500 to 1100 hPa standard range

Digital Accuracy* 0.2 hPa (25°C)
0.3 hPa (-50°C to +60°C)

Analog Accuracy** 0.05% of analog pressure range

Analog Temperature Dependence** 0.0017% of analog pressure range per °C (25°C reference)

* Defined as ±1 standard deviation from NIST traceable pressure reference. Includes non-linearity, hysteresis, repeatability, and calibration uncertainty.

** Defined as ±1 standard deviation from ideal analog output. Total analog output accuracy is the root square of digital accuracy, analog accuracy, and analog temperature dependence.

Output Rate 1.8 Hz (max) to 1 per minute

Current Output 4 to 20 mA
12-bit resolution (1 in 4000)
Selectable pressure range:
500 to 1100 hPa (standard)

Serial Output Full-duplex RS-232
Half-duplex RS-485
1200 to 38400 baud
Continuous ASCII text
Polled ASCII text
NMEA
0.01 hPa resolution

Supply Voltage 7 to 30 VDC
25 mA max in 4-20 mA mode
7 mA with serial I/O only

Case Fiber-reinforced thermoplastic

Weight 44 g (1.5 oz)

2.0 INTRODUCTION

Barometric Pressure Sensor is a versatile electronic barometer featuring high accuracy, low power, wide operating temperature range, and calibrated 4-20 mA output, and RS-232/485 serial data I/O.

The 4-20 mA output and RS-485 serial I/O make ideal for commercial and industrial applications that commonly use these signals. Full scale current output may be set to span any portion of the 500 to 1100 hPa operating range. Serial output options include continuous or polled ASCII text output or NMEA marine output. The sensor is supplied with the following standard configuration:

Current Output 4-20 mA = 500 to 1100 hPa
RS-232 Continuous ASCII text output
10 samples averaged
1.8 Hz update rate

3.0 INSTALLATION

The sensor operates over a temperature range of -50°C to +60°C and must remain dry. Electrical connections are made with the 5-position terminal plug included with the sensor. Jumper settings may be used to select operating options. Access jumpers

by loosening two screws in the sensor enclosure and removing the cover. See Appendix A for wiring details and jumper settings.

4.0 OPERATION

Operation begins approximately 1 second after power is applied. Output will appear after a delay determined by the number of samples averaged and the output rate. With default values (1.8 Hz output and 10 samples averaged), output begins after an initial 5 second delay then remains continuous at the 1.8 Hz rate. Parameters for output rate and number of samples averaged may be changed using software commands.

4.1 CURRENT OUTPUT

Calibrated 4-20 mA current output is always active. The connection scheme appears in the Appendix A Wiring Diagram.

The current output scale may be mapped to any part of the 500 to 1100 hPa pressure range using the IOUT HI and IOUT LO software parameters. The standard setting maps 4 to 20 mA with 500 to 1100 hPa. With this setting:

$$\text{hPa} = 37.5 * \text{mA} + 350$$

Effective resolution is about 0.15 hPa

Greater effective resolution may be achieved by mapping the current output to a narrower range of pressure with the IOUT HI and IOUT LO parameters. For example, with IOUT LO set to 950 hPa and IOUT HI set to 1050 hPa:

$$\text{hPa} = 6.25 * \text{mA} + 925$$

Effective resolution is about 0.025 hPa

Please see section 4.3 below for details on changing the IOUT HI and LO parameters.

4.2 SERIAL OUTPUT

may be configured for either full-duplex RS-232 or half-duplex RS-485 serial communication. For RS-232 serial communication, both jumpers at P3 must be in position '2'. For RS-485 serial communication, both jumpers at P3 must be in position '4'. Jumper location details appear in the Appendix A Wiring Diagram.

Standard baud rate is 9600 but any of several available baud rates between 1200 and 38400 may be used.

Jumpers at P1 and software parameter settings determine serial output format.

Format	Description
Continuous ASCII Text (standard)	9600 baud 10 sample average 1.8 Hz output
Polled ASCII Text	9600 baud 10 sample average Output when polled
Marine NMEA	4800 baud 10 sample average 1 Hz output
Software	Output parameters determined by software settings

See Appendix A Wiring Diagram for details on jumper P1 configuration options and serial output examples.

In POLLED ASCII mode, the unit sends data only after receiving a poll command. The poll command is Ma! where 'a' is the address value. The standard address is '0' (ASCII 48) for a poll command of M0! Please see section 4.3 for details on changing the poll address.

Upon receiving a properly addressed poll command, the unit immediately sends data.

4.3 SOFTWARE COMMANDS

Software commands sent via serial communication may be used to set operational parameters. The sensor must be configured for serial communication and connected to a PC or other compatible device using a program like HyperTerm.

New settings are stored in temporary memory and must be burned to flash with command CMD420 to be retained.

Note that the P1 jumper must be configured for SOFTWARE format to change baud rate, sample average count, and output rate parameters.

Although the sensor may receive commands at any time, measurement output may be paused by sending three ESC (ASCII 27) characters or CMD300 1. While paused, COMMAND mode is indicated by a ">" prompt. All commands must be terminated with a carriage return CR (ASCII 13).

Use ">" to list available commands as shown below.

>2

```
YOUNG 61302L SERIES BAROMETER V2.02
-----
CMD100 n OUTPUT PERIOD (0-60 sec)
CMD105 n AVG SAMPLE COUNT (0-32)
CMD110 n OUTPUT FORMAT
          (1=ASCII 2-POLLED 3=NMEA 4=RAM 5-DIAG)
CMD120 n MULTIPLIER (10000 = 1.0000)
CMD125 n OFFSET (hPa x 100)
CMD130 n SEA LEVEL CORRECTION (hPa x 100)
CMD140 n IOUT RANGE HI (500-1100)
CMD142 n IOUT RANGE LO (500-1100)
CMD150 c POLL ADDR CHAR
CMD160 n BAUD RATE (38400, 9600, 4800, 2400, 1200)
CMD300 n 1=STOP, 2=RUN
CMD310 n FORCE IOUT (0-20000 FULL SCALE)
CMD400 n 1=RPT TEXT, 2=RPT CODE ONLY
CMD410 GET CAL TABLE
CMD420 STORE SETUP PARAMETERS
```

CMD100 n sets output period in seconds. When set to zero, the output rate is 1.8 per second.

CMD105 n sets the average sample count. Higher sample count yields more stable readings but will lengthen the startup delay.

CMD110 n sets output format.

CMD120 n sets the output multiplier. 10000 represents 1.0000

CMD125 n sets the output offset in hPa x 100

CMD130 n sets the sea level correction in hPa x 100
$$= [P_{\text{unadst}} * (\text{Mult} / 10000)] + [(\text{Offset} / 100)] + (\text{Correction}_{\text{Sea Level}} / 100)$$

CMD140 n sets the IOUT Pressure Range HI

CMD142 n sets the IOUT Pressure Range LO
IOUT Pressure Range HI must be greater than IOUT Pressure Range LO

CMD150 c sets the poll address character. Any ASCII character from '0' (ASCII 48) to 'z' (ASCII 122) may be used.

CMD160 n sets the baud rate. Acceptable values are 38400, 9600, 4800, 2400, and 1200. Note that the baud rate change occurs immediately after the command is received. Therefore, in order to continue communicating, the serial communication program that issued the command must also change to match.

CMD300 n causes the sensor to pause or resume measurement. 1 = Stop, 2 = Run.

CMD400 n causes the sensor to issue a report summarizing parameter settings.
1 = Text (parameter values and labels)
2 = Code Only (parameter values only).

CMD420 burns the current parameter settings to flash memory. This step **must** take place to retain changes to settings otherwise parameters will revert to previous values at the next power up.

5.0 MAINTENANCE

barometer requires no regular maintenance. Periodic calibration certification, if required, is available from the factory.

6.0 WARRANTY

This product is warranted to be free of defects in materials and construction for a period of 12 months from date of initial purchase. Liability is limited to repair or replacement of defective item.

7.0 CE COMPLIANCE

This product complies with European CE requirements for the EMC Directive. Please note that shielded cable must be used.

4055 Grass Valley Hwy Ste 102
Auburn, CA 95602

NovaLynx Corporation
PO Box 240
Grass Valley CA 95945-0240
530 823-7185 • Fax 530 823-8997
www.novalynx.com • nova@novalynx.com