

## For Weather Stations and Sensors

This application note describes various mounting solutions for non-penetrable flat surfaces. The mounting platforms described in this note can be used to stabilize and ballast the Davis Mounting Tripod (#7716) and/or other Davis weather instruments. The mounts can be used whenever and wherever a user wants to avoid installing lag screws or bolts into a flat roof or mounting surface (e.g., school or office building installations).

This note describes three mounting options: the first two are user-constructed; the third can be purchased from a non-Davis retailer. The user-constructed mounts are designed to secure the Davis Mounting Tripod (#7716) that can then support the Davis weather stations; the Sensor Mounting Arm, and/or individual sensors. The purchased mount, on the other hand, includes a vertical mounting pipe that can directly accommodate the sensing equipment described above (i.e., without the tripod).

### Mount 1: Using Concrete Parking Bumpers as Ballast Components

Part Description	Quantity
Parking Bumper, concrete, 36" long*	2
Steel angle, 2"x2"x1/8" thick, 39" long**	2
Steel angle, 2"x2"x1/8" thick, 32" long**	2
3/8" bolt, 6" long***	4
3/8" flat washer	4
3/8" nut	4
5/16" machine screw, 3/4" long	7
5/16" flat washer	7
5/16" split lock washer	7
5/16" nut	7
Indoor/Outdoor Carpet, 36"x 44"	1

\* Parking bumper available from precast concrete supplier, approximately \$10.00 ea.

\*\* Galvanized steel angles are preferred—otherwise paint. One 6 ft. long angle will make one 32" piece and one 39"-40" piece.

\*\*\* 3/8" bolt length determined by actual bumper used.

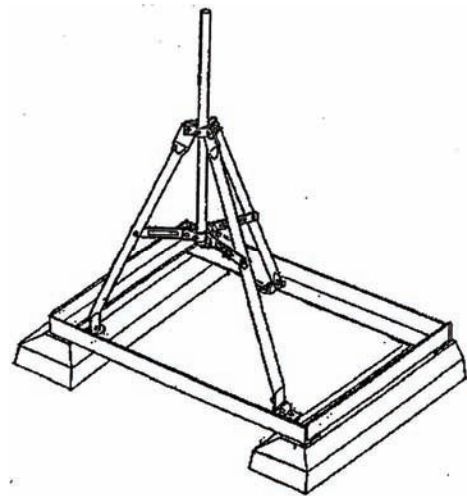

Figure 1. Using Concrete Bumpers as Ballast

### Assembly

1. Cut angles to length, drill and construct frame. Use 5/16" screws, flat washers, split lock washers, and nuts at corners.
2. Chisel a counterbore in bottom of parking bumpers at holes and install 3/8" bolts and flat washers from below. Drill 1/2" holes in frame to match hole locations in parking bumpers. Secure frame to bumpers with 3/8" nuts.
3. Place tripod on frame, mark hole locations, and drill 3/8" holes. Secure tripod to frame with 5/16" screws, flat washers, split lock washers, and nuts. Note: if roof has a slight slope, use a longer 5/16" nut under the tripod leg that is on the angle with the single mounting hole. Position the frame so that this single leg is on the downhill side.
4. Place nuts or washers between top of frame and bottom of tripod foot to bring the mounting pole vertical.
5. A 36" x 44" piece of indoor/outdoor carpet can be placed under the parking bumpers to protect the roof.

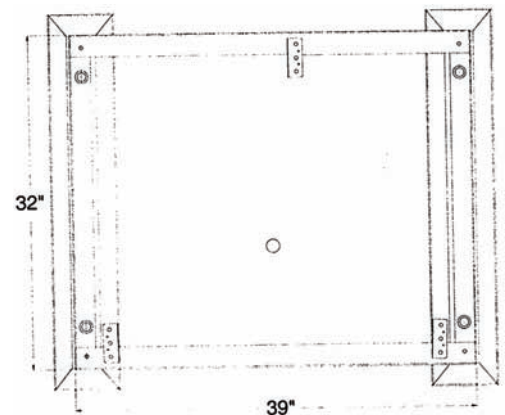

Figure 2. Tripod on Parking Bumpers

**MOUNT 2: Using Concrete Cinder Blocks as Ballast Components**

Part Description	Quantity
Concrete Cinder Blocks*	6
Steel angle, 2"x2"x1/8" thick, 39" long**	2
Steel angle, 2"x2"x1/8" thick, 32" long**	4
5/16" machine screw, 3/4" long	11
5/16" flat washer	11
5/16" split lock washer	11
5/16" nut	11
Indoor/Outdoor Carpet, 33"x 40"	1

- \* Cinder blocks available from precast concrete supplier, approximately \$1.50 ea.
- \*\* Galvanized steel angles are preferred – otherwise paint. One 6 ft. long angle will make one 32" piece and one 39"-40" piece.

**Assembly**

1. Cut angles to length, drill, and construct frame. Attach angles with 5/16" screws, flat washers, split lock washers, and nuts at corners.
2. Place tripod on frame, mark hole locations, and drill 3/8" holes. Secure tripod to frame with 5/16" screws, flat washers, split lock washers, and nuts. Note: if roof has a slight slope, use a longer 5/16" nut under the tripod leg that is on the angle with the single mounting hole. Position the frame so that this single leg is on the downhill side. Place nuts or washers between top of frame and bottom of tripod foot to bring the mounting pole vertical.
3. A 33" x 40" piece of indoor/outdoor carpet can be placed under the frame to protect the roof.

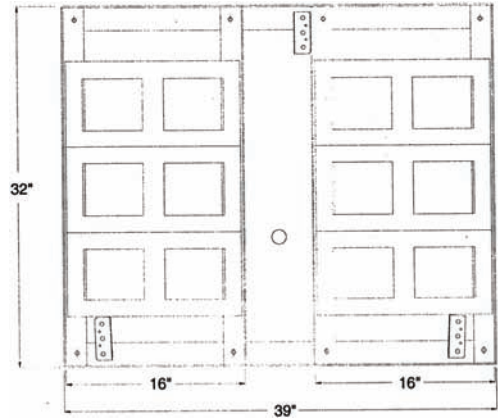

Figure 3. Tripod on Cinder Block Frame (With Blocks)

### MOUNT 3: Available For Purchase

Non-penetrating roof mounts frequently are used for small satellite dishes, wireless cable dishes, and antennas. Many are stocked or can be ordered through local wireless communications equipment suppliers or ham radio stores.

Rohn Model FRM 238SP5 has a 5-foot-tall, 2-3/8-inch-diameter pipe and can be purchased for approximately \$80.00 (cinder blocks not included). The Radian Company carries and manufactures Rohn products. Contact Radian for availability:

6718 West Plank Road  
Peoria, IL 61604  
Phone: (309) 697-4400  
Fax: (309) 697-5612  
E-mail: rohnproducts@radiancorp.com

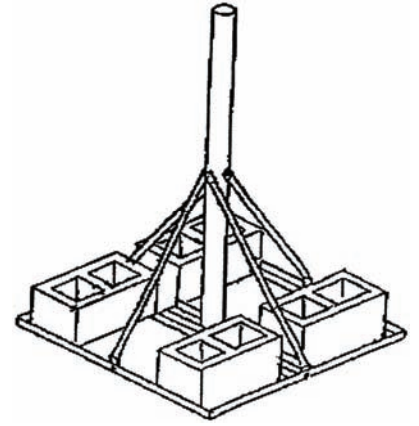

Figure 4. The Rohn Model FRM 238SP5 Mount

The 2-3/8-inch outside diameter pipe may be used for the Davis Sensor Mounting Arm. For EZ-Mount and Wireless installations, the extension tube can be attached with U-bolts or hose clamps (must be adapted by the user).

### SAFETY NOTES

- Before installing, verify that the roof material and supporting structure have been investigated and found to be capable of withstanding all loads imposed by the weather station and its support platform. Confirm that the supporting surfaces, anchors, and/or safety cables, if required, are in conformance with all applicable local, state, and federal requirements.
- All installations must be grounded to meet applicable codes.

**Note:** Any metal object can and may attract a lightning strike, including your weather station or tripod. If lightning strikes your station or strikes somewhere nearby, the station's internal electronics may suffer anywhere between little to extensive damage. The station itself has been designed with considerable surge protection, but to safeguard nearby equipment and structures, we recommend following local recommendations on properly grounding your installation. For more information, contact your local lightning protection authority and/or refer to the following articles:

- MIL-HDBK-419A: *Grounding, Bonding, and Shielding for Electronic Equipments and Facilities*, 29 Dec 1987.
  - National Fire Protection Association, 1997: *Standard for Installation of Lightning Protection Systems*, 1997 ANSI/NFPA 780, National Fire Protection Association, Quincy, MA.
  - NEC, *National Electrical Code, 1996 Edition*: National Fire Protection Information, Quincy, MA.
- Ballast weights should be determined by a local professional engineer to prevent overturning or sliding at the design wind load.

Use common sense. The weather station is not very heavy or large. To check that the platform can withstand winds of up to 70 mph, pull on the top of the mounting arm with 60 lbs. to 70 lbs. of force. If higher winds are anticipated, use additional ballast or anchoring. If there is any chance of the platform sliding off the roof, install an anchor cable.

---

**DAVIS**   
**Davis Instruments**

3465 Diablo Avenue, Hayward, CA 94545 U.S.A.  
Phone: 510-732-9229 • Fax: 510-732-9188  
sales@davisnet.com • <http://www.davisnet.com>