

With Vantage Pro® and Vantage Pro2™

INTRODUCTION

WeatherLink for Alarm Output can be incorporated in any Vantage Pro or Vantage Pro2 weather station. It monitors data from the display console or Weather Envoy™ and the user settings configured via PC. Up to eight test conditions may be logically grouped together to determine when to activate or deactivate any of four contact closures. Nine different logical test conditions are available. These may be used to control external systems, indicators, or equipment.

NOTE: The Alarm Output is not suitable for any use in which the health or safety of any person or the value or protection of valuable property is dependent on its operation.

OPERATION OF THE OUTPUTS

All user controls are configurable via PC. The following is an overview of the functions available to the user in this product. The functions are accessible via the separate Streaming Data Utility program that installs with WeatherLink for Vantage Pro and Vantage Pro2.

As shown in the Figure below, the user determines whether the outputs will be open or closed when their respective alarms are active (Circuit Behavior):

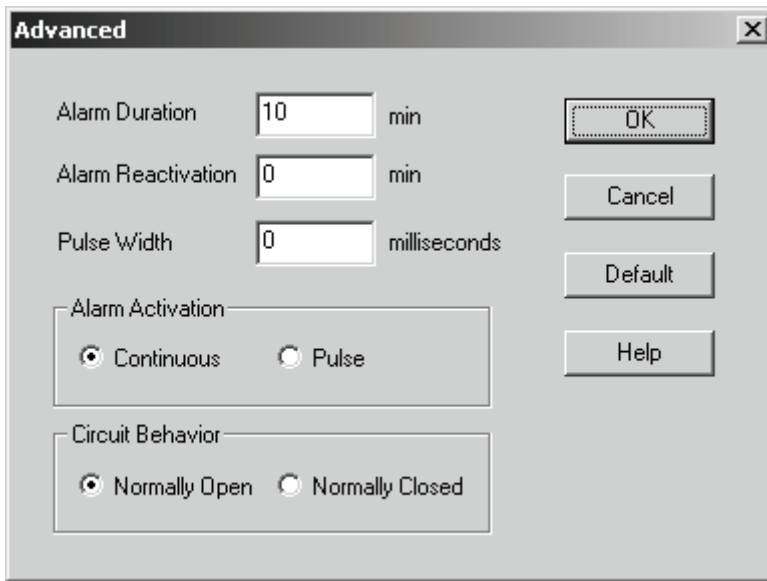

The user may verify the functioning of the Alarm Output by using the Output Test feature.

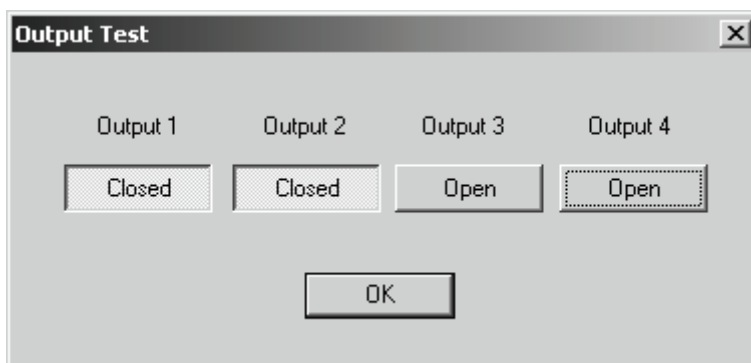

The following table lists the alarm parameters available to the user and the types of test conditions that can be applied to each parameter. The Time alarm is active for one minute when using the Equal test condition. All other outputs remain active as long as their corresponding alarm conditions are true. Additionally, the user may extend the activation or non-activation times as needed (to be discussed later).

Weather Parameters	Greater Than or Less Than	Between or Not Between	True or False	Trending	Equal	Minus (Difference)	Missing
Time	X*	X*			X	X*	X
Barometer value	X	X		X	X	X	X
Inside Temperature	X	X		X	X	X	X
Inside Humidity	X	X		X	X	X	X
Inside Dewpoint	X	X		X	X	X	X
Inside Heat Index	X	X		X	X	X	X
Barometer Trend Arrow (April 24, 2002 Vantage Pro firmware revisions or later):							
Rising Rapidly			X				X
Rising Slowly			X				X
Steady			X				X
Falling Slowly			X				X
Falling Rapidly			X				X
Rain Rate	X	X		X	X	X	X
Daily Rain	X	X		X	X	X	X
Monthly Rain	X	X		X	X	X	X
Yearly Rain	X	X		X	X	X	X
Storm total rain	X	X		X	X	X	X
Daily ET	X	X		X	X	X	X
Monthly ET	X	X		X	X	X	X
Yearly ET	X	X		X	X	X	X
Outside Temperature	X	X		X	X	X	X
Outside Humidity	X	X		X	X	X	X
Outside Dewpoint	X	X		X	X	X	X
Outside Heat Index	X	X		X	X	X	X
Current Wind Speed	X	X		X	X	X	X
10 Minute Average Wind Speed	X	X		X	X	X	X
Wind Direction (when two thresholds are used, they are used to define a sector of the compass to check). The smallest difference between the two is used as the sector to check, i.e., you cannot set a sector larger than 180 degrees	X**	X**		X**	X**	X**	X
Wind Chill	X	X		X	X	X	X
Solar Radiation	X	X		X	X	X	X
UV Radiation	X	X		X	X	X	X
Temperature (#6382) or Temperature/Humidity Stations (#6372)							
Extra Temperature Tx ID # 1	X	X		X	X	X	X
Extra Temperature Tx ID # 2	X	X		X	X	X	X
Extra Temperature Tx ID # 3	X	X		X	X	X	X
Extra Temperature Tx ID # 4	X	X		X	X	X	X

* relative to midnight

** relative to north (0° or 360°)

Weather Parameters	Greater Than or Less Than	Between or Not Between	True or False	Trending	Equal	Minus (Difference)	Missing
Extra Temperature Tx ID # 5	X	X		X	X	X	X
Extra Temperature Tx ID # 6	X	X		X	X	X	X
Extra Temperature Tx ID # 7	X	X		X	X	X	X
Extra Temperature Tx ID # 8	X	X		X	X	X	X
Extra Humidity Tx ID # 1	X	X		X	X	X	X
Extra Humidity Tx ID # 2	X	X		X	X	X	X
Extra Humidity Tx ID # 3	X	X		X	X	X	X
Extra Humidity Tx ID # 4	X	X		X	X	X	X
Extra Humidity Tx ID # 5	X	X		X	X	X	X
Extra Humidity Tx ID # 6	X	X		X	X	X	X
Extra Humidity Tx ID # 7	X	X		X	X	X	X
Extra Humidity Tx ID # 8	X	X		X	X	X	X
Soil & Leaf Sensors							
Leaf Wetness 1	X	X		X	X	X	X
Leaf Wetness 2	X	X		X	X	X	X
Soil Moisture 1	X	X		X	X	X	X
Soil Moisture 2	X	X		X	X	X	X
Soil Moisture 3	X	X		X	X	X	X
Soil Moisture 4	X	X		X	X	X	X
Leaf Temperature 1	X	X		X	X	X	X
Leaf Temperature 2	X	X		X	X	X	X
Soil Temperature 1	X	X		X	X	X	X
Soil Temperature 2	X	X		X	X	X	X
Soil Temperature 3	X	X		X	X	X	X
Soil Temperature 4	X	X		X	X	X	X
Transmitter Battery Status							
Transmitter ID # 1 Battery OK?			X				
Transmitter ID # 2 Battery OK?			X				
Transmitter ID # 3 Battery OK?			X				
Transmitter ID # 4 Battery OK?			X				
Transmitter ID # 5 Battery OK?			X				
Transmitter ID # 6 Battery OK?			X				
Transmitter ID # 7 Battery OK?			X				
Transmitter ID # 8 Battery OK?			X				
Diagnostic Values							
Console Battery Voltage	X	X		X	X	X	X
ISS Reception	X	X		X	X	X	X
Repeater Battery Status (Vantage Pro2 only)							
Repeater A Battery OK?			X				
Repeater B Battery OK?			X				
Repeater C Battery OK?			X				
Repeater D Battery OK?			X				
Repeater E Battery OK?			X				
Repeater F Battery OK?			X				
Repeater G Battery OK?			X				
Repeater H Battery OK?			X				

Four outputs labeled 1 through 4 are available to the user as tabs on the main configuration dialog box. Each row represents an individual logical test condition. At the end of the first row is the option to logically group more test conditions together to form an overall test condition for the particular output (to be discussed later).

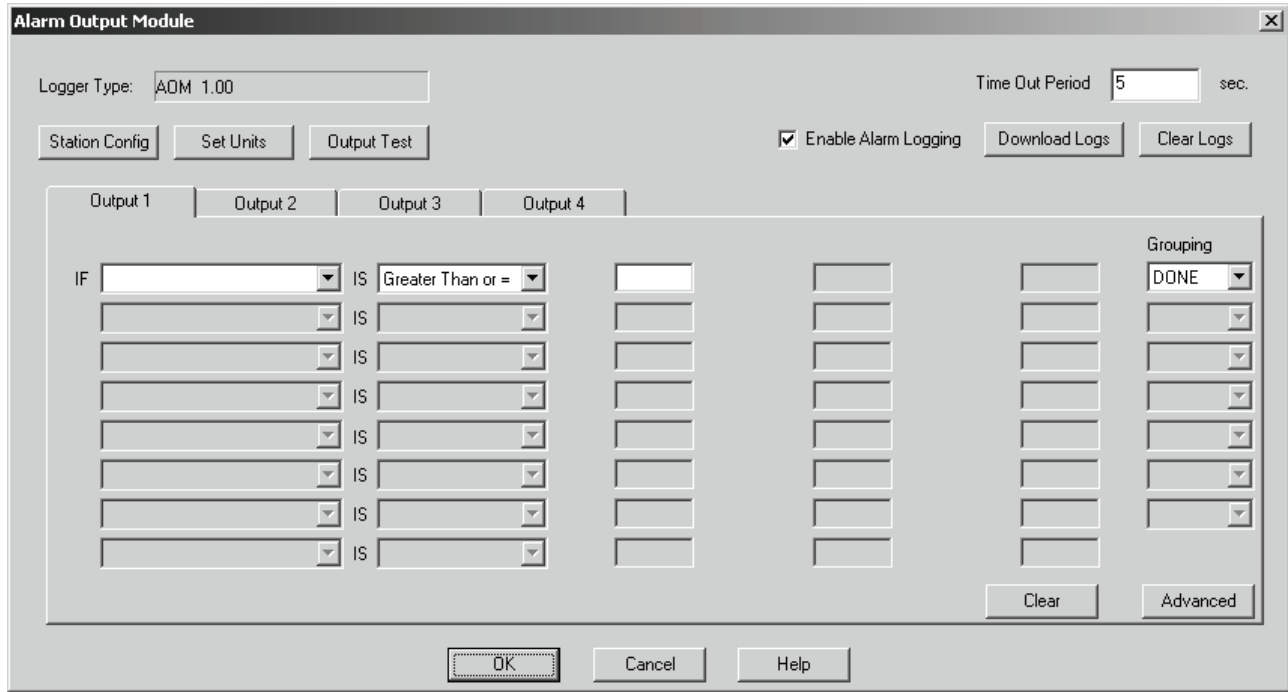

Upon power up (powering the console or Envoy), the data logger will briefly test all four outputs by closing the circuit (turning on the output). It is recommended that you disconnect any equipment attached to the data logger outputs before rebooting the console or Envoy. Afterward, all output contacts are kept open until configured by the user.

CONTACT SPECIFICATIONS

The “contact” closure is provided by a photo-coupled MOS device. Because it is a solid-state device, it is not subject to arcing and contact-welding as are mechanical relays. However, since it is a solid-state device, it will be damaged by operation beyond its ratings, which are:

- Nominal Load Voltage: 28 V AC or 48 V DC, Maximum
- Peak Voltage: ± 60 V, Maximum
- Load Current: ± 1.8 A, continuous Maximum at 77°F (25°C),
derated to 0.7 A at 185°F (85°C)
- ON Resistance: 0.12 Ohm, Maximum

The contacts are suitable for direct connection to low-voltage systems with contact-closure inputs, such as thermostats, security systems, and irrigation controllers. They are also suitable for switching power to low-power loads such as buzzers, doorbells, light-duty relays and solenoids, small lamps, etc. If heavier loads are to be controlled, or if special timing or logical requirements must be met, intermediate devices must be used, as discussed below.

Driving Loads

The paragraphs below discuss in general terms some of the possibilities for controlling higher-power circuits from the Alarm Outputs. This is intended to be only an introduction to the issues. It does not give sufficient information to enable one to design or install a specific circuit.

Unless you are qualified to do so, do not attempt to wire electrical circuits. Wiring should be done only by a qualified professional. FIRE and ELECTROCUTION are hazards of improper wiring.

HIGHER VOLTAGE and CURRENT

When the load voltage or current exceeds the ratings of the Alarm Output contacts, you'll need a relay (or maybe two) between the Alarm Outputs and the circuit to be controlled. Relays come in all shapes, sizes, and flavors; the categories include mechanical, reed, and solid state relays.

Mechanical Relays contain a coil and moving arm with electrical contacts. When current passes through the coil, a magnetic field is generated; this moves the arm and thus closes the contacts, completing the circuit between the higher-power equipment and its power source. Figure 1a illustrates the idea. The "Power Source" in the figure might be a 12- or 24-Volt wall power adapter or a 24-Volt doorbell transformer.

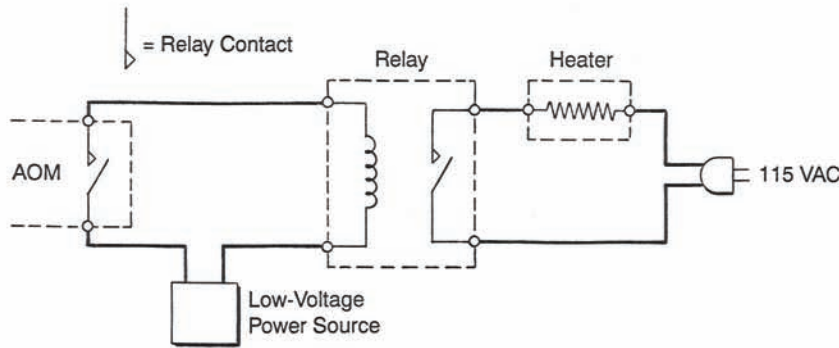

Figure 1a. Use of a Relay to Switch a Heater.
(Simplified circuit.)

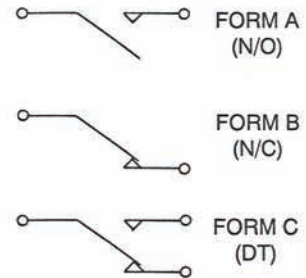

Figure 1b. Contact Forms

Mechanical relays are usually specified in terms of their coil voltage and resistance (or current) and their contact ratings. The coil specifications must match the ratings of the Alarm Output (AOM) contacts and the low-voltage power source, and the relay's contact ratings must match the characteristics of the driven load and its power source. Low-voltage relays often have coil voltage specs of 6, 12, or 24 Volts DC and 24 Volts AC. Any of these is suited for the Alarm Output contacts. The coil resistance must be high enough that the current rating of the Alarm Output's contact is not exceeded over the temperature range. Surge protection, as discussed below, must be added to this simplified circuit to protect the Alarm Output from the relay coil's inductive surge.

A good choice might be a 24-Volt coil with resistance of 160 Ohms or greater or a 12-Volt coil with resistance of 80 Ohms or greater. The current should be 150 mA or less. One possible choice:

Relay #275-218 from Radio Shack has a 75-mA, 12V coil and contacts rated for 10A at 125VAC.

Mechanical relays often have multiple poles (or sets of contacts). These can be used for switching multiple circuits or multi-phase voltages, or they can provide auxiliary outputs for driving indicators or relay logic. The relay's contacts may be one of three types: Form A, normally-open; Form B, normally-closed; Form C, double-throw. Figure 1b shows the contacts in their inactive state.

A Reed Relay is a form of mechanical relay in which the coil is wound around a reed switch. This relay tends to be more sensitive; coil current requirements are often in the range of 10 to 20 mA. Because the reed contacts are not as husky as those of a typical mechanical switch, their contact ratings are lower, but some heavy-duty versions have ratings of 0.7Amps at 150 VAC.

Solid State Power relays are usually intended for AC loads. They use semiconductor devices (SCRs or triacs) rather than mechanical contacts to switch the power. Their advantages include high sensitivity, no contact bounce or arcing, and no mechanical wear or degradation. A typical input requirement is 3 to 30 Volts AC or DC with only a few mA of current; such a unit may switch 50 mA to 50 Amps at 48 to 280 VAC. The circuit would be very much like that in figure 3. Digi-Key Corporation offers a "Solid State Relay Design Guide," part number 92138-ND, for about \$20.

The solid state relay (SSR) does have limitations. These include --

- Voltage Transient Sensitivity. Noise spikes from inductive loads, lightning, and other sources can damage the semiconductor components. Snubber circuits (see below), MOVs, or other surge suppressers may be needed to protect the relay. With protection the SSR is extremely reliable.

- Voltage Drop. The relay causes a drop of about 1 Volt, creating a power dissipation of 1 Watt per Amp of load current. This heat must be pulled out in order to keep the relay's temperature below 125°C.
- Leakage Current. When open, a mechanical relay breaks its circuit completely. A solid-state relay will allow a leakage current of one to 10 mA to pass.

Inductive Loads

Inductive loads, such as motors, solenoids, mechanical relays, and even long wires, can cause voltage surges when they are switched off. When current flows, the inductor stores energy in its magnetic field; when the circuit is opened, the field returns this energy, forcing the current to continue to flow. The result is a voltage "spike." This spike can cause arcing of mechanical relay contacts and breakdown of solid-state relays. SSRs are susceptible, not only to the magnitude of the spike, but to its rate of rise (dV/dt).

In the case of DC-driven inductive loads, such as mechanical relays, solenoids, and DC motors, a diode placed across the inductor will shunt this current and reduce the spike (the upper circuit in Figure 2a). A resistor in series with the diode will dissipate the current surge faster and cause the relay to drop sooner, but this may be of little value in a slow-acting Alarm Output circuit. A 1N4001 diode is a good choice for protecting the Alarm Output.

In AC circuits the answer is resistor-capacitor "snubber" circuits, which may be built-in to some SSRs or added to the circuit (the lower circuit in Figure 2a). The selection of optimum resistor and capacitor values is often a matter of trial and error, but the values shown in Table 2 are good as a starting point.

Figure 2b shows an example of small-motor switching by the Alarm Output. The diode protects the Alarm Output from the inductive surge of the mechanical relay; the snubber prevents arcing and burning of the relay contacts. When switching power to large motors, one must be aware that they can act as generators when still turning.

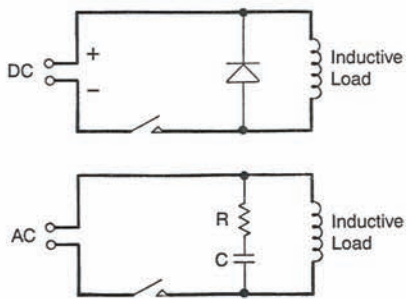

Figure 2a. DC Circuit with Diode Clamp.
AC Circuit with Snubber.

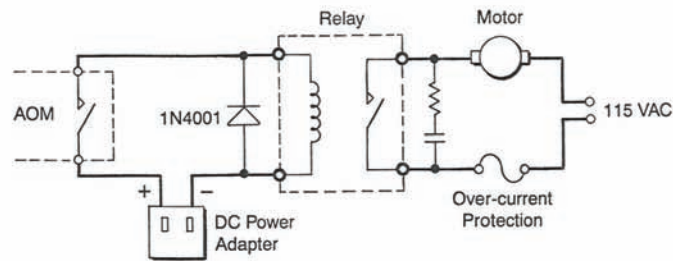

Figure 2b. Alarm Output (AOM) Motor-control
Circuit.

Table 2. Typical Snubber Circuit Values

Load Current Amps rms	Resistance Ohms	Capacitance uF
5	47	0.047
10	33	0.1
25	10	0.22
40	22	0.47

Source: Motorola Thyristor Device Data

Mechanical Motion

To convert an electrical signal to a simple push-pull mechanical force or short movement, a solenoid is the usual component of choice. A solenoid is much like a relay: its coil generates a magnetic field which moves an armature. In the case of the relay, the moving armature makes and breaks an electrical contact. The solenoid makes the armature motion available; one use might be the opening or closing of a slide lock.

Solenoids are specified in terms the following characteristics:

- AC or DC
- Push or Pull
- Coil Voltage and Resistance
- Length of armature movement
- Force exerted by the armature.

The design considerations for switching power to drive the coil of a solenoid are essentially the same as those for driving the coil of a relay.

Power Sources

If the circuit to be controlled must be driven by a voltage or current (as opposed to a contact closure) and if low-voltage power is not available from the circuit being controlled, a separate low-voltage power source is required. As mentioned above, this might include any of the following alternatives, among others --

DC Power: 5 to 48-Volt power supply or plug-in AC/DC power adapter.

AC Power: 5 to 28-Volt plug-in AC/AC adapter or a transformer.

Timing and Logic

If the output does not have the right timing characteristics, some advanced features or the use of some simple circuits may be the answer. Note that any of the following techniques may be used in combination with each other and with the load-driving techniques discussed above.

Using the Outputs

The outputs (1 and 2) of the Alarm Output are closed by one Alarm output and opened by another Alarm. These may be used to generate very simple control functions. For example, if output 1 is being used to control power to a cooling fan in a livestock barn where temperature is being measured, one might use the Greater Than Temperature alarm on 1 to activate it and the Less Than Temp alarm on 2 to deactivate it. If the High Temp alarm is set at 90°F and the Low Temp alarm at 80°F, the fan will start when the temperature in the barn reaches 90°F, and it will continue to run until the temperature drops to 80°F.

This will insure that the fan will not start and stop frequently if the temperature hovers around the setpoint.

Timing

Through the Advanced features in the configuration software on the PC, the user may

- extend the activation time (Alarm Duration) or
- delay the reactivation (Alarm Reactivation) of an alarm once it is inactive

for up to 255 minutes (4 hours, 15 minutes).

The image shows a software dialog box titled "Advanced" with a close button (X) in the top right corner. The dialog contains the following controls:

- Alarm Duration:** A text input field containing "10" followed by the unit "min".
- Alarm Reactivation:** A text input field containing "0" followed by the unit "min".
- Pulse Width:** A text input field containing "0" followed by the unit "milliseconds".
- Alarm Activation:** A group box containing two radio buttons: "Continuous" (which is selected) and "Pulse".
- Circuit Behavior:** A group box containing two radio buttons: "Normally Open" (which is selected) and "Normally Closed".
- Buttons:** On the right side of the dialog, there are four buttons: "OK", "Cancel", "Default", and "Help".

Logic

Using the configuration software, the user may logically group several test conditions together to control one output. You may choose:

- OR if you want this condition or any of the other conditions you set to trigger an alarm.
- AND if you require this condition and all of the other conditions you set be present to trigger an alarm
- XOR if you want an alarm to trigger if any one of the conditions you are checking becomes valid, but not all.

The screenshot shows the 'Alarm Output Module' configuration window. At the top, it displays 'Logger Type: AQM 1.00' and 'Time Out Period: 5 sec.'. Below this are buttons for 'Station Config', 'Set Units', 'Output Test', 'Enable Alarm Logging' (unchecked), 'Download Logs', and 'Clear Logs'. The main area is divided into four tabs: 'Output 1', 'Output 2', 'Output 3', and 'Output 4'. The 'Output 1' tab is active, showing a grid of 8 rows for configuring test conditions. Each row has an 'IF' dropdown (the first is 'Outside Temperature'), an 'IS' dropdown (the first is 'Greater Than or ='), a numerical value field (the first is '70'), and a unit field (the first is '°F'). To the right of the grid is a 'Grouping' dropdown menu with options 'DONE', 'OR', 'AND', and 'XOR'. At the bottom of the grid are 'Clear' and 'Advanced' buttons. The window has 'OK', 'Cancel', and 'Help' buttons at the very bottom.

If you wish to logically group more than 8 test conditions together, relay contacts can be easily connected to generate a wide variety of logical functions, all based on combinations of AND and OR logic circuits and the ability to INVERT a logic signal. The following discussion assumes that a CLOSED contact represents a TRUE condition (the Alarm Output contacts are Normally-Open, closed when active).

OR Function: Figure 3a. Shows two contacts, A and B, connected in parallel. The circuit output, C, is TRUE if A OR B is TRUE. (C is closed if A OR B is closed.)

AND Function: In Figure 3b, the contacts are connected in series. This provides the AND function: C is TRUE only if A AND B are TRUE. (C is closed if A AND B are closed.) An example: if the OK contact is connected in series with the 1 contact in the Latch example above, the fan motor will be on only when the temperature conditions call for it and the Alarm Output is continuing to receive good data.

↳ = Relay Contact

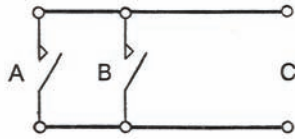

Figure 3a.
Contacts in Parallel.
C = A or B

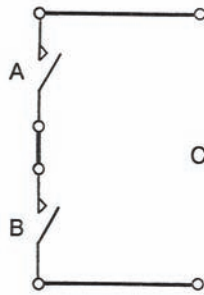

Figure 3b.
Contacts in Series.
C = A and B

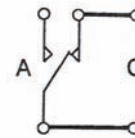

Figure 3c.
Inversion.
C = not A

If the opposite logic polarity is assumed, namely that an OPEN contact represents a TRUE condition (switch is normally-closed, the AND and OR circuits are reversed: 3a is an AND circuit and 3b is an OR (the proof is left to the student).

INVERTING Function: The INVERSE of a relay logic condition is provided by the normally-closed contacts. For example, if relay A in Figure 3c is active when TRUE, its normally-closed contact(s) will be logically TRUE when A is NOT TRUE.

Component Sources

Electrical and electronic components are available from many sources. Following are just a few:

COMPANY	COMPONENTS CARRIED
Radio Shack Local store 1-800-843-7422 www.radioshack.com	Transformers Power adapters Mechanical relays Reed relays Solid-state Relay Resistors, capacitors, diodes
Digi-Key 1-800-344-4539 1-218-681-6674 fax::1-218-681-3380 www.digikey.com	Transformers Power Adapters Mechanical Relays Reed Relays ZNR (MOV) Surge Suppressors Solid-state Relays Timers Resistors, capacitors, diodes
Allied Electronics 1-800-433-5700 (\$25 minimum order) www.alliedelec.com	Transformers Power adapters Mechanical relays Reed relays MOV Surge Suppressors Solid state relays Solenoids Timers Resistors, capacitors, diodes
Mouser 1-800-346-6873 www.mouser.com	Transformers Power adapters Mechanical relays Reed relays TVS Surge Suppressors Solid state relays Resistors, capacitors, diodes
Securitron Magnalock Corp 1-800-MAGLOCK www.securitron.com	Programmable multi-function Timer

DAVIS
Davis Instruments

3465 Diablo Avenue, Hayward, CA 94545 U.S.A.
Phone: 510-732-9229 • Fax: 510-732-9188
sales@davisnet.com • http://www.davisnet.com